

Contents list available at JMCS

Journal of Mathematics and Computer Science

Journal Homepage: www.tjmcs.com

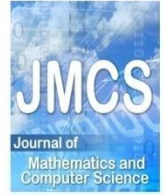

Comparing performance of PID and fuzzy controllers in the present of noise for a Photovoltaic System

Amir Gheibi
Department of Electrical
Engineering, Shahid Bahonar
University of Kerman
a.gheibi@eng.uk.ac.ir

S. Mohammad Ali Mohammadi
Department of Electrical
Engineering, Shahid Bahonar
University of Kerman

Malihe M. Farsangi
Department of Electrical
Engineering, Shahid Bahonar
University of Kerman

Article history:

Received September 2013

Accepted October 2013

Available online October 2013

Abstract

The main advantage of using fuzzy controller for a hard nonlinear system, for instance solar cell, is the reduction of effect of uncertainty in system control. In this paper, this prominent quality has been tried to represent more with comparing fuzzy and PID controllers. Although PID controller is a linear controller but it can control many nonlinear and industrial systems with a much better performance. Howbeit it has less robustness against uncertainty. We have indicated that if an uncertainty for example a noise or a changing in the parameter of system, enters during the operation of system, fuzzy controller will decrease the effect of it better than PID controller.

Keywords: fuzzy logic control, Boost converter, PID controller, Maximum power point tracking, Solar cell

1. Introduction

Utilizing solar cells provides many advantages including no fuel cost, no pollution, and no need for maintenance equipment. According to a nonlinear voltage-power characteristic solar cell, Output power of solar cell is nonlinear and time varying Depending on environmental conditions such as light intensity and temperature which it will be changed. So every minute maximum power point (MPP) is needed to be traced. There are many innovative methods, and all of them use this fact that the power-voltage curve slope has a value of zero in the maximum point. In a generalized classification, these methods can be divided into four main categories: Control Algorithm [1-2], Control Variable [3-6], Math-based Methods [7-8] and Intelligent Control [9-13].

Serial and/or parallel cells generate photovoltaic array (PVA) in order to receive more power. Fuzzy method is much sought after due to its suitable answer towards uncertainty present in the system, and

its desirable speed and precision. This method gives desirable answers even with limited changes in system parameters [9-11].

If light intensity and temperature don't change, the MPP will occur in a constant voltage. With modifying level of voltage to this constant voltage will be tracked MPP. But if environmental conditions change with time, voltage in MPP will change too. In this case for a better performance, a more complicated controller is required which its parameters with changing atmospheric conditions changes [12].

A Boost converter usually is used for modifying levels of voltage. Boost converters have a MOSFET that receives control signal from controller and then the same of a switch, it becomes on or off. Proper levels of voltage will be produced and finally maximum power from output of PVA is received.

2. Boost converter

A proposed maximum power point tracking (MPPT) scheme obtained by varying the duty ratio for DC/DC boost converter has been successfully [14-15]. The Boost converters are widely used in PV generator as an interface between the PV panel and the load, allowing the follow-up of the MPP. Fig.1 indicates boost converter with a PWM comparator.

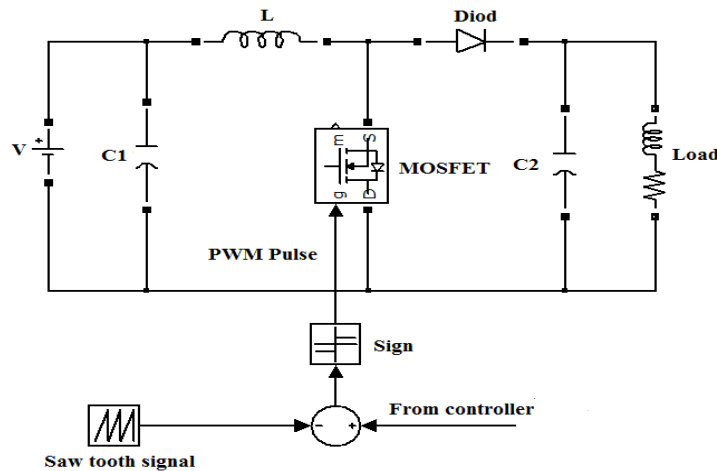

Figure 1: Boost converter with a PWM (pulse wide modulation) comparator

The PWM comparator is used to compare the command voltage from control signal with a saw tooth signal in order to obtain the PWM control signal in the gate of the MOSFET transistor. An R_{Mpp} resides in the MPP point, which shows that the output resistance of photovoltaic occurs in the point of maximum power. R_{Mpp} has a small value, and a boost converter is employed in order to obtain maximum system performance. The boost converter can alter input resistances larger to equal R_{Mpp} , and due to the fact that photovoltaic resistance is higher than R_{Mpp} resistance in high radiations (near 1000 W/m^2), and considering that during day time tracking photovoltaic resistance is usually higher than R_{Mpp} resistance, therefore the boost converter is used more often for tracking purposes.

3. Characteristics of controllers

The non-linear nature of solar cell system requires a kind of controller which not only at the constant temperature conditions and irradiation based on what the controller is designed, works appropriately

but also has an acceptable function at the variable temperature conditions as well as the irradiation close to design conditions.

3.1. Fuzzy logic control

Fuzzy logic controller (FLC) is made of fuzzification, knowledge and inference unit and defuzzification are indicated in Fig.2. The fuzzy control requires that variable used in describing the control rules should be expressed in terms of fuzzy set notations with linguistic labels. The rule base that affiliates the fuzzy output to the fuzzy inputs is derived by understanding the system behavior. After the rules have been evaluated, the last step to complete the fuzzy control algorithm is to calculate the crisp output of the fuzzy control with the process of defuzzification. The implementation of the fuzzy controller in term of type1 fuzzy sets has two input variables; the error $e(t)$ and the error variation $\Delta e(t)$, In MPP:

$$e(t) = \Delta P(t) / \Delta V(t) \tag{1}$$

$$\Delta e(t) = e(t) - e(t - 1) \tag{2}$$

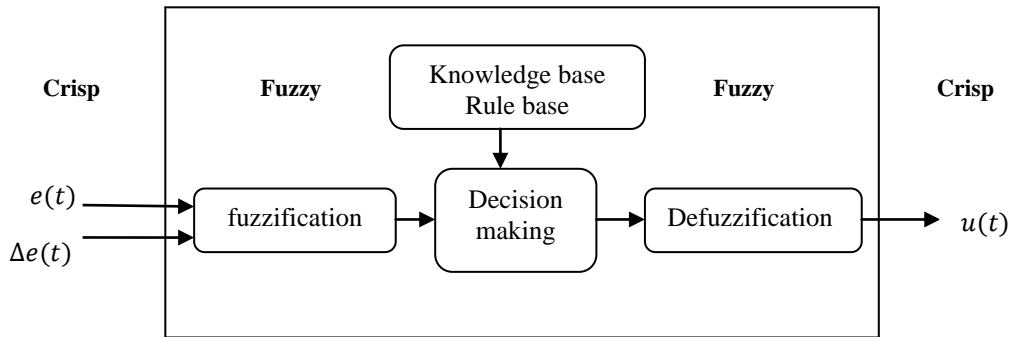

Figure 2: Structure of a Fuzzy Logic Control

3.2. PID controller

After the parameters of PID controller were tuned by Ziegler-Nichols method, it can be applied to the solar cell system. In this method first, the gain of a under control system is being increased so that the response of the system starts to fluctuate. The system in this situation has been placed on the border between stability and instability. Then in this state, the values of the gain and the frequency of fluctuations are measured. These two values are called respectively K_u and T_u . Finally when three parameters of PID controller were calculated by using Table 1, K_f and f_f , the designed controller is applied to photovoltaic in order to receive maximum power.

Table 1: To obtain the Parameters of PID controller by using Ziegler-Nichols method

$k_p = .5k_u$	$T_i = .\Delta T_u$	$T_d = .1r\Delta T_u$
---------------	---------------------	-----------------------

Both of fuzzy and PID controllers use mathematical tools to analyze a system. Although there is a considerable difference between them. The classic controller is designed based on a mathematical model of a process, so it designed for this model. But intelligent controller is planned by means of expert knowledge, and this knowledge leads to some rules for designing it [16].

4. Simulation

At first, both of fuzzy and PID controllers are applied to a photovoltaic system without any imported noise in perimeter of simulink of MATLAB software. We supposed that temperature is 25°C and irradiance is 400W/m². According to Fig.3, the output power of photovoltaic with each of controllers tracks MPP identically. But when the noise occurs to photovoltaic system, response of the system for each of them differs. According to figure 4, in the simulation, the noise has been imported in feedback way Because most of the noises occur to systems at the time of measuring.

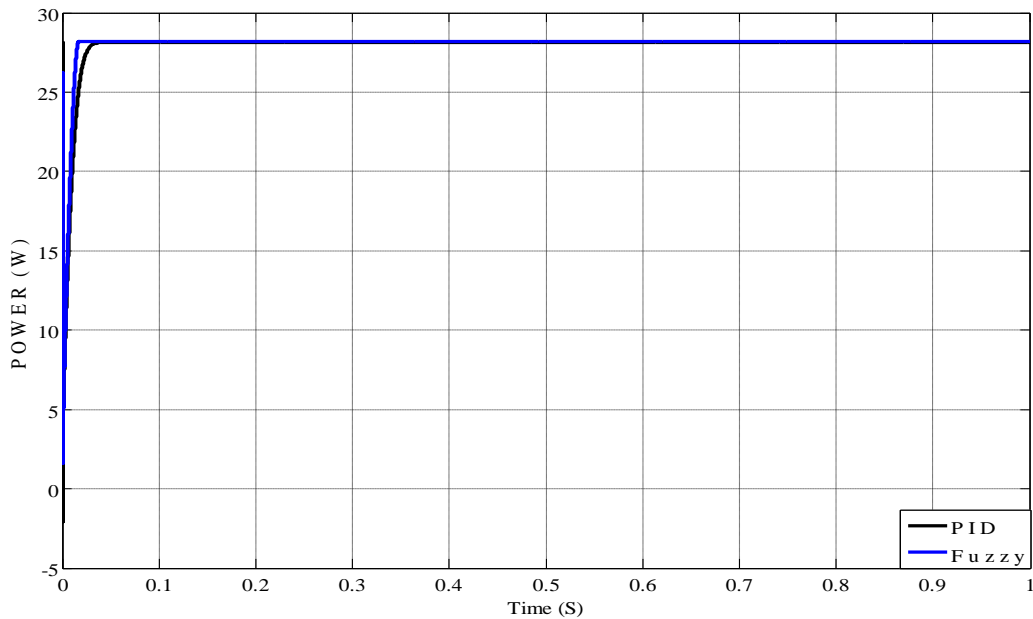

Figure 3: Output power of photovoltaic by PID and fuzzy controllers

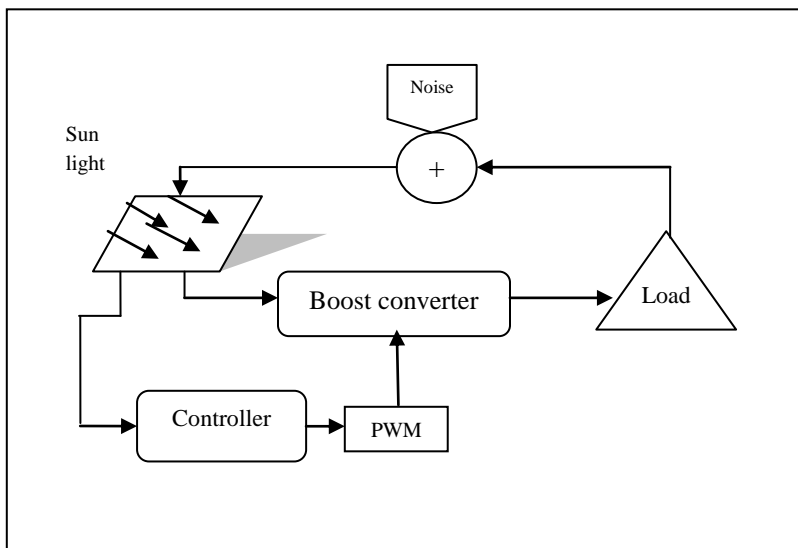

Figure 4: Structure of photovoltaic system with applied noise

Assume an expected noise is imported to system. Equation (3) shows intensity of this noise:

$$SNR = \frac{\int |S|^2}{\int |\eta|^2} = \frac{P_{signal}}{P_{noise}} \quad (3)$$

Because most signals have very wide dynamic range, SNR is usually expressed in terms of the logarithmic decibel scale, SNR (db):

$$SNR = 10 \log_{10} \left(\frac{P_{signal}}{P_{noise}} \right) \quad (4)$$

We insert the noise with the same power to each of them. In this state SNR for PID controller is 26 decibel and for fuzzy controller is 45 decibel. As it is seen in Fig.5, at the presence of noise, the mean value of the tracked output power by using fuzzy controller is more than PID controller, because fuzzy controller can decrease the effects of uncertainty.

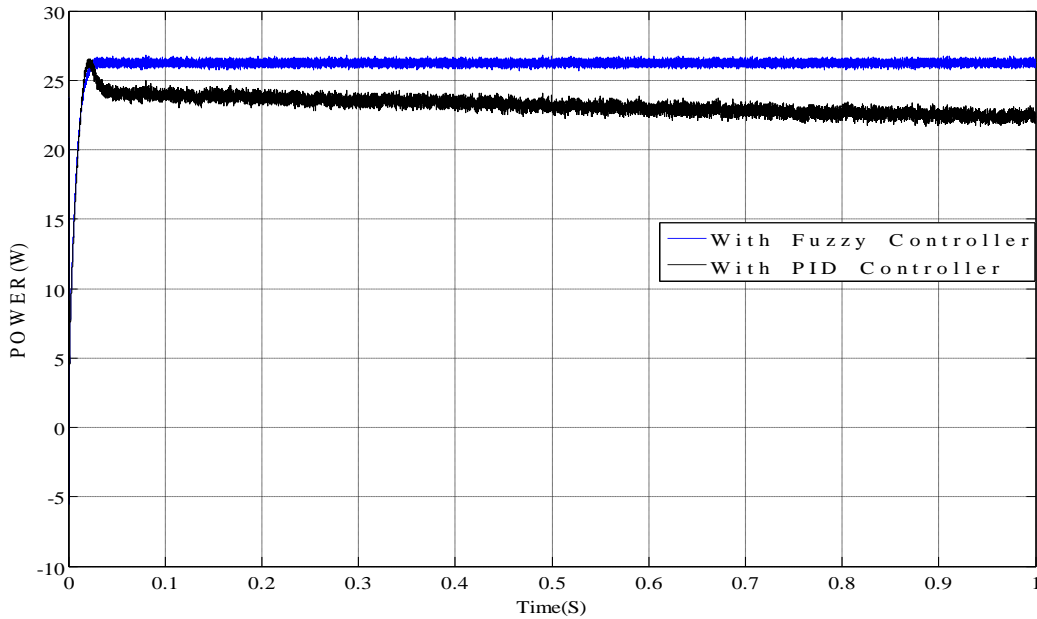

Figure 5: Output power of photovoltaic by PID and fuzzy controllers at present of the noise

Response of systems by using fuzzy method is desirable even with limited changes in system parameters. But using of classic methods caused to wide error in this situation. For instance, if changing of irradiance is the same Fig.6, the output power of photovoltaic in two control state will be according to Fig.7 and Fig.8. But if the system parameters changes are extended (e.g. extensive changes in radiation or ambient temperature or load, in a short period), fuzzy method can't work suitable, and tracking the point of maximum power will be followed severe errors. So we need

complicate controller that its parameters are changed proportional to changing at parameters of system (adaptive control) [12], [17].

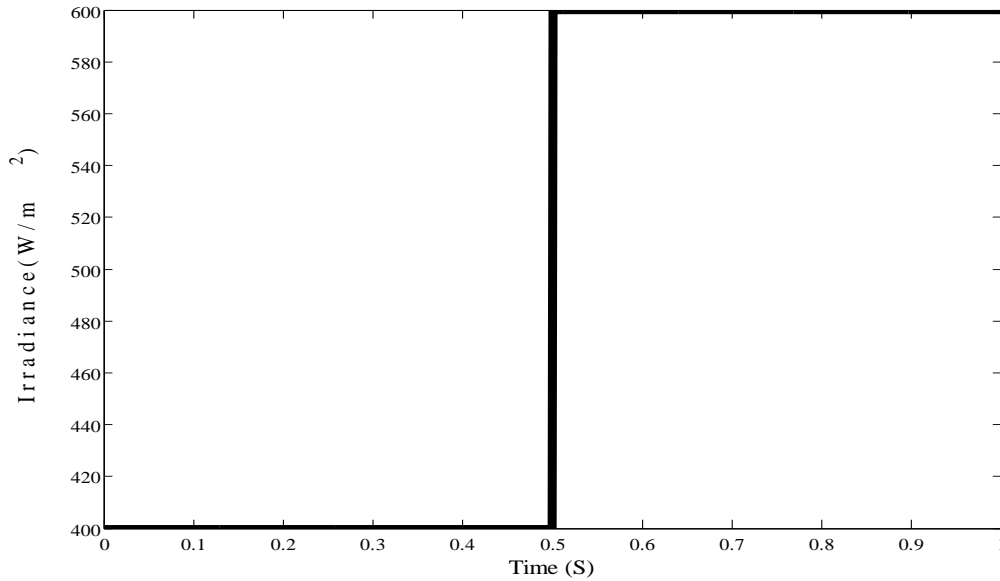

Figure 6: changing of irradiation with time

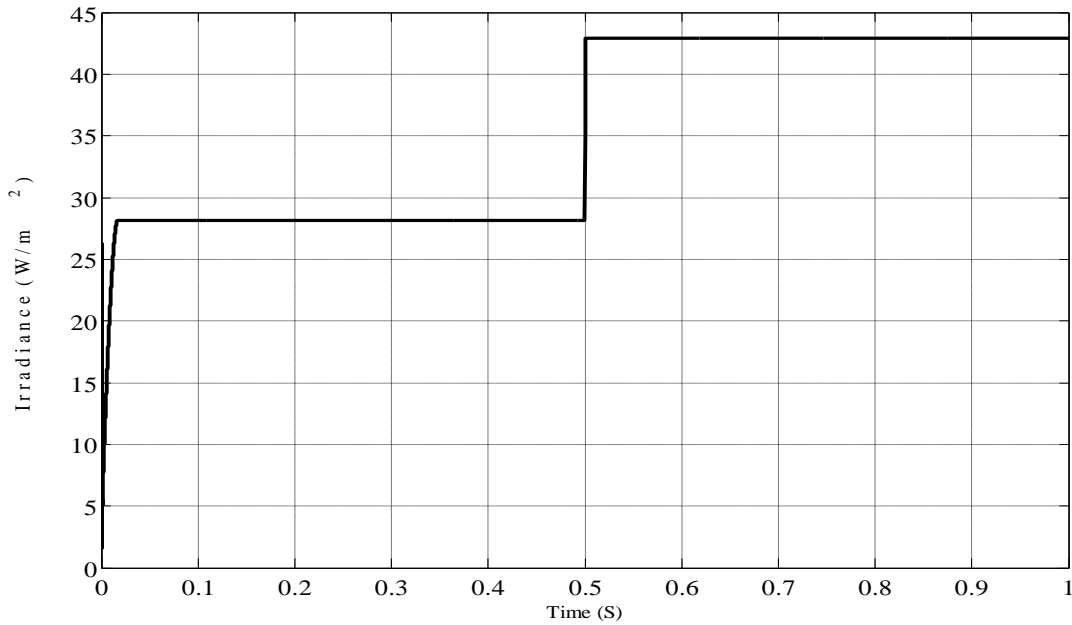

Figure7: Output power of photovoltaic by fuzzy controller

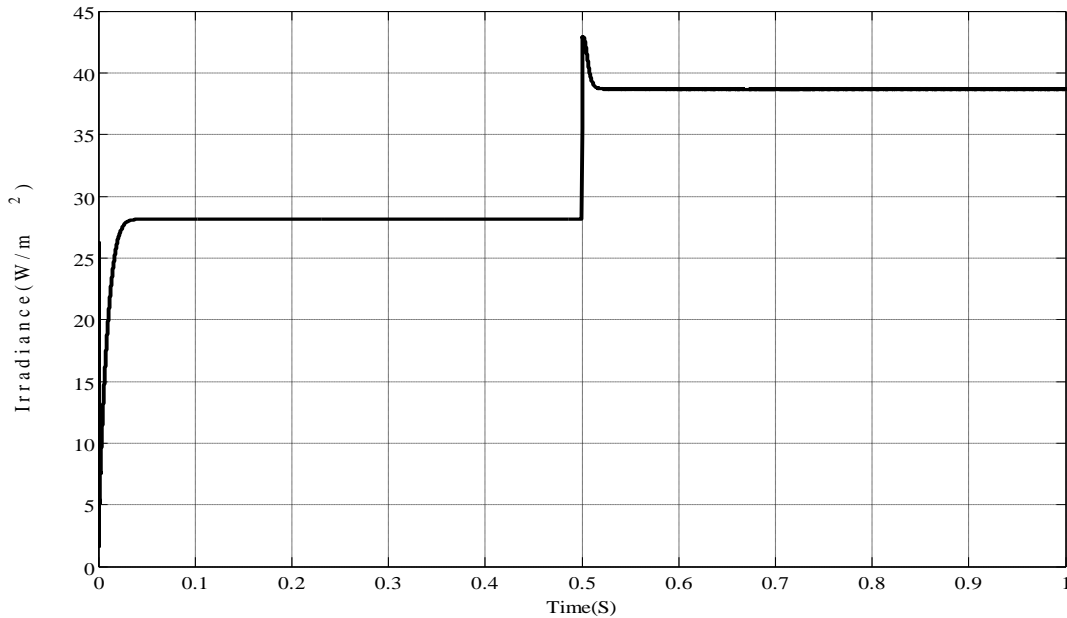

Figure 8: Output power of photovoltaic by PID controller

5. Conclusion

Fuzzy controller controls the system under control on-line. Classic controllers such as PID, are designed based on a mathematical model of the system and purposes of control, so they have less Immunity in facing the noise. Entrance of the noise to the system is inevitable if even all of the principles of a design are considered. It is too important to have a controller that is robust in facing the noise. Also when the parameter of a system (for example radiation in system of photovoltaic) is changed, MPPT can be difficult with PID controllers. Thus having a controller with a high flexibility is very important. If these variations are limited, fuzzy controller will be better choice than PID controller.

Reference

- [1] N. Femia, G. Petrone, Optimization of perturb and observe maximum power point tracking method, IEEE Power Electron (2005) 963-973.
- [2] P. Wolfs and Quan Li, A current-sensor-free incremental conductance single cell MPPT for high performance vehicle solar arrays, Power Electronics Specialists Conference(PESC). 37th Annual IEEE (2006) 1-7.
- [3] SMM Wolf, JHR Enslin, Economical PV maximum power point tracking regulator with simplistic controller, Power Electronics Specialists Conference (PESC). Annual IEEE (1993) 581-587.
- [4] Fumihiko Umeda, Masato H. Ohsato, Gunji Kimora, Mitsuo Shioya, New control method of resonant dc-dc converter in small scaled photovoltaic system, Power electronics specialists conference (PESC). 23th Annual IEEE (1992) 714-718.
- [5] C. Dorofte, U. Borup, and F. Blaabjerg, A combined two-method MPPT control scheme for grid-connected photovoltaic systems, power electronics and applications. European Conference (2005) 1-10.
- [6] CHEN Yu-yun , MAN Yong-kui, Constant current-based maximum power point tracking for photovoltaic power systems, EDT from IEEE (2010) 3422-3425.
- [7] N. Mutoh, T. Matuo, Prediction-data-based maximum power point tracking for photovoltaic power generation system, IEEE. Power Electron conference. In Proc. 33rd Annu (2002) 1489-1494.

- [8] Jiyong Li, Honghua Wang, Maximum Power Point Tracking of Photovoltaic Generation Based on the optimal Gradient method, IEEE (2009) 1-4.
- [9] I. H. Altas, Sharaf, A. M, A novel maximum power fuzzy logic controller for photovoltaic solar energy systems, Renewable Energy journal (2008) 388–399.
- [10] Xiangdong Qi, Hong Li, Application of Fuzzy Logic and Immune Response Feedback for PV Generating System, IEEE. Department of Electronic and information (2007) 119-124.
- [11] F. Bouchafaa, I. Hamzaoui, A. Hadjammar, Fuzzy Logic Control for the tracking of maximum power point of a PV system, Energy Procedia (2011) 633-642.
- [12] Nopporn, Patcharaprakiti, Suttichai Premrudeepreechacharn, Yosana Sriuthaisiriwong, Maximum Power Point Tracking Using adaptive fuzzy logic control for grid-connected photovoltaic system, Renewable Energy (2005) 1771-1788.
- [13] FENG Dongqing, MA Junlei, A MPPT PV system control method based on fuzzy neural network, Computing Technology and Automation journal (2007) 26: 25-28.
- [14] J. M. Enrique, E. Duran, M. Sidrach-de-Cardona, J. M. Andujar, Theoretical assessment of the maximum power point tracking efficiency of photovoltaic facilities with different converter topologies, Solar Energy (2007) 31-38.
- [15] C. Elmas, O. Deperlioglu, H. H. Sayan, Adaptive fuzzy logic controller for DC-DC converters, Expert Systems with Applications, Elsevier (2009) 1540-1548.
- [16] S. K. M. Mashhadi, M. Z. Savzevar, J. G. D. Yekan, Simulation of Temperature Controller for an Injection Mould Machine using Fuzzy Logic, The Journal of Mathematics and Computer Science, (2013) 7:33-42.
- [17] K. J. Astorm, B. Wittenmark, Adaptive control, 2nd ed. Addison-Wesley Longman Publishing Co. Inc, Boston, USA, 1994.